

University of Wisconsin-Parkside

Enriching Minds

Changing Lives



# ***“Partnerships Enhance Success”***

## **Update on Research, Economic Development, and Innovation Activities**

October 10, 2013

UW Board of Regents REDI Committee

# ***“Presentation Overview”***

**Introductions**

**Faculty Engagement**

**Procured Partnership**

**UW-Parkside and REDI**

- Talent and Economic Development Team
- Research Successes
- WCCR and Regional Alliance
- Programs that work (SBDC, SEG, Ranger Link)

# ***“Faculty Engagement”***

Dr. Abey Kuruvilla

Associate Professor of Business

Making a difference in our region and beyond...

# Aurora Medical Center

Rehabilitation

Food Services Layout

Nurse Medication

Inpatient Pharmacy

Space Utilization

Food Services Operations

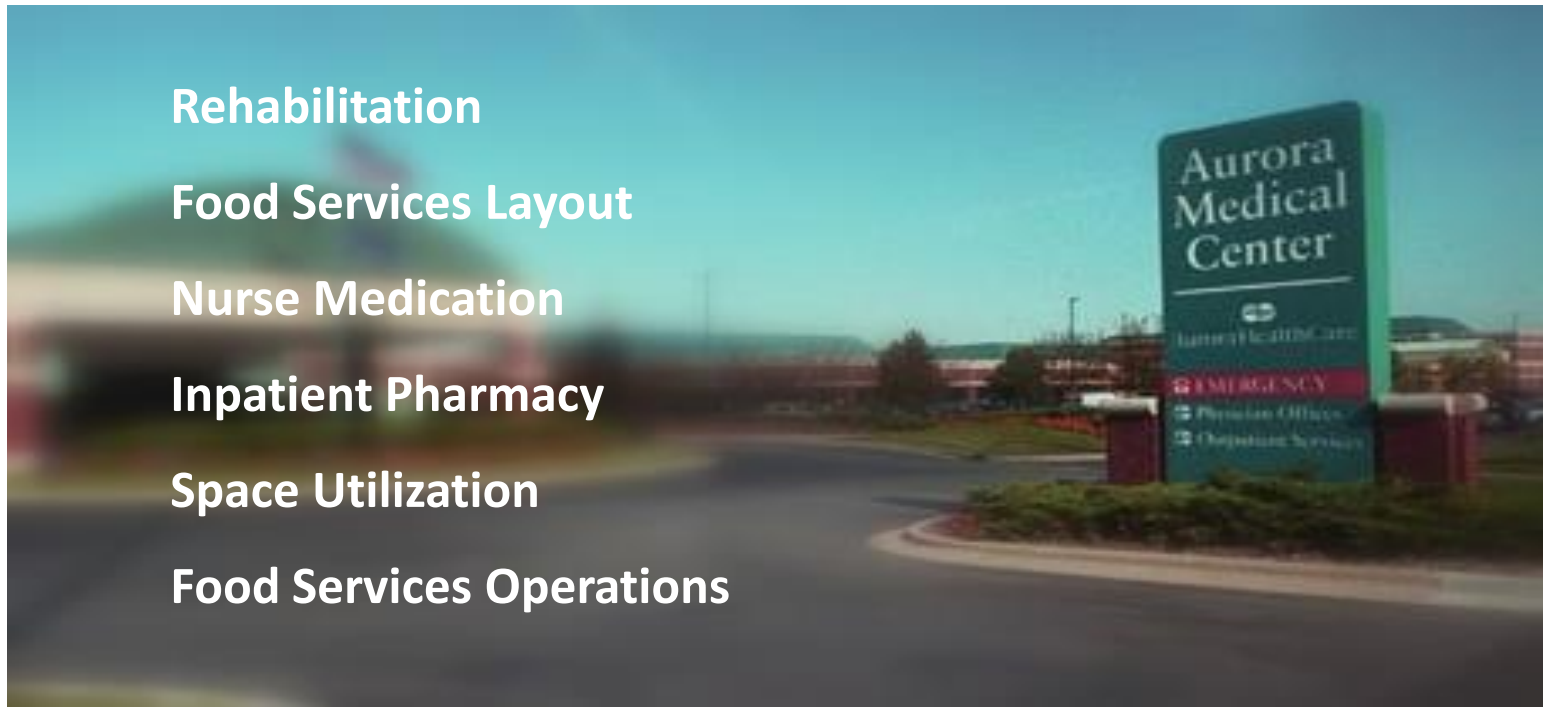

Enriching Minds... Changing Lives

# FedEx



Guest Speakers

Live MBA Case Studies

Field Visits

Internships

Enriching Minds... Changing Lives

## RKCAA



***“Our partnership with UW-Parkside...is priceless”***

*Essie Allen, Associate Director*



Enriching Minds... Changing Lives

# Skies Fall Media & BelleTV

Hired by Racine to Revamp CAR25

Summer Interns From UW-Parkside

Business and Communication Departments

2 Interns and 1 Full-Time Station Director

Brown Bag Luncheon – 35 Interested Students



# An Operations Management Model

**Class Logistics**

**Grade Distribution**

**Diversity Groups**

**Stories**

- **Dept. of Corrections**
- **Emergency Medical Services**
- **LOVE Inc.**
- **and a couple of hundred more...**

# ***“Procubed LLC”***

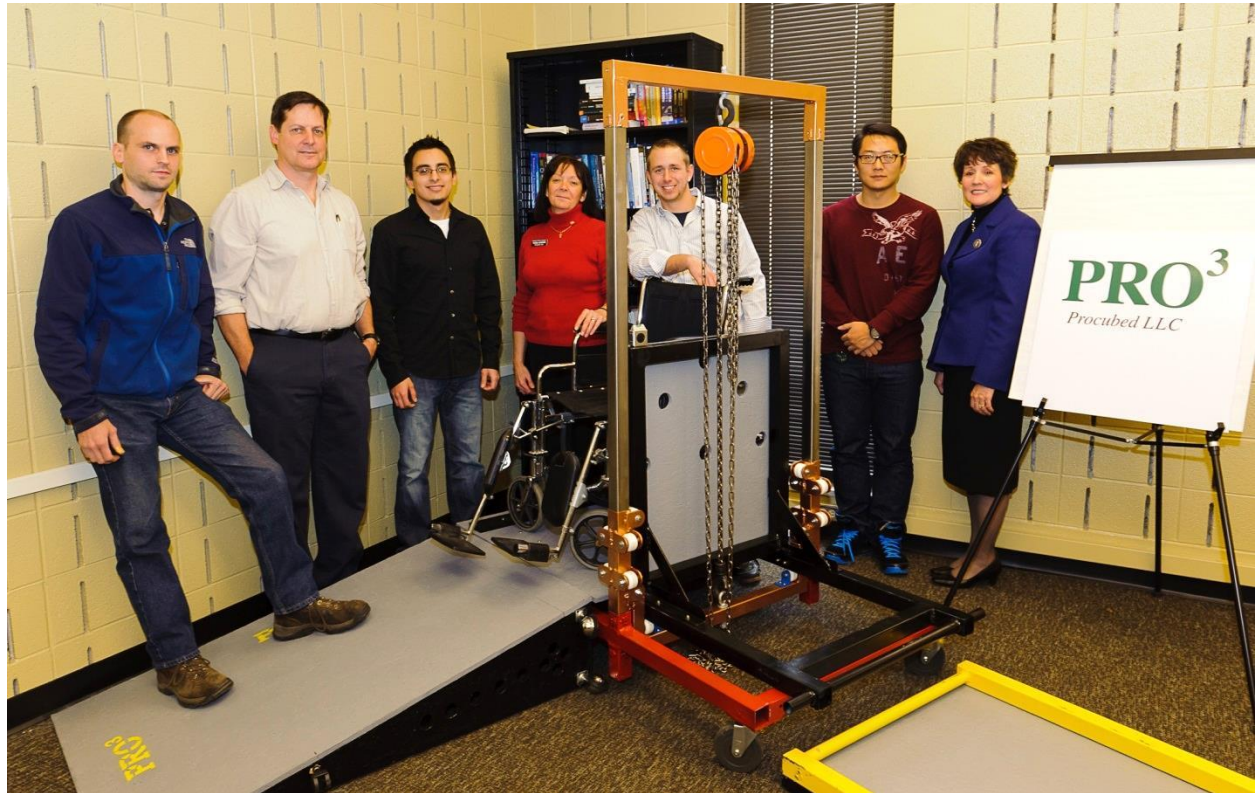

Enriching Minds... Changing Lives

# PRO<sup>3</sup>

*Procubed, LLC*

*Kenosha, Wisconsin*

*Engineering, design, machine building, testing and validation*



A New Dimension in Mobility

Enriching Minds... Changing Lives

Examples of work done by Procubed for regional industry.

Supports efforts to develop the LRM technology

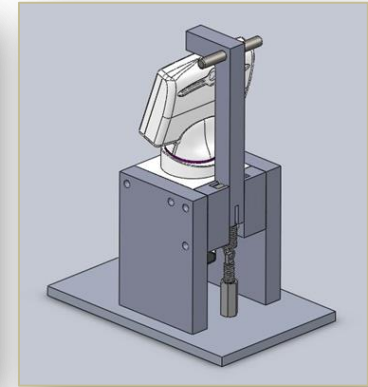

*"Pays the bills and hones the skills."*

**PRO<sup>3</sup>**

*Procubed, LLC*

Enriching Minds... Changing Lives



# Why Matters



- Demand at 1% and rising including disabled Veterans
- The revolutionary LRM Drive is the “Secret Sauce”
- With LRM; more power, less injury
- Reduced cost of care
- Lifestyle upgrade
- Completely portable
- More capable
- No pain

Enriching Minds... Changing Lives

# Linear to Rotary Motion (LRM)



Dr. Peter Knight organized business students to work on the market research and business strategy.

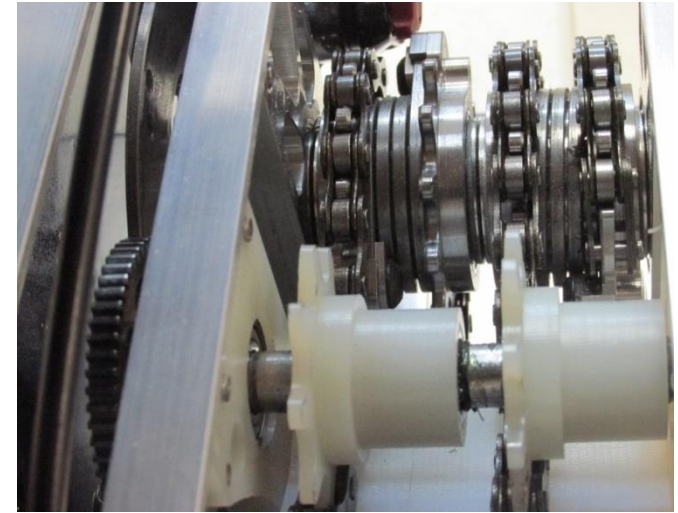

First application of the LRM device is on a manual wheelchair – lightweight, foldable and painless.



Weighted test dummy per ASTM standards. Students named it "Fanny."



Built test equipment to evaluate performance.

# UW-Parkside Collaboration

- Business students performed extensive market research
- Helped with test data collection and analysis
- Organized and carried out extensive surveys and focus groups
- Wrote and presented a comprehensive market analysis based on their research
- Dr. Michele Gee's Advanced MBA students developed business strategy options
- Dr. Knight and two of his MBA students are finalizing Procubed's marketing plan



Where



Is Going:

- Collaboration with HERL and UW Parkside (see: [www.herl.pitt.edu](http://www.herl.pitt.edu))
- SBIR/NIH grant
- US and international patents
- FDA requirements
- User trials
- DME collaboration
- Direct connection with VA
- License the 5D wheelchair
- Develop new products based on the LRM technology

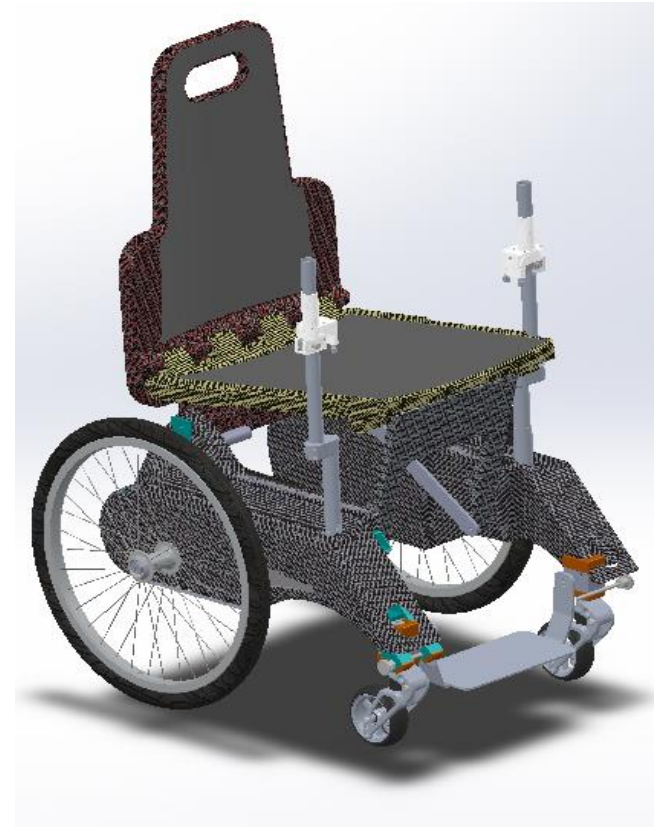

Enriching Minds... Changing Lives

**PRO<sup>3</sup>**

*Procubed, LLC*

# 5D Wheelchair



Linear to Rotary Motion Application

Enriching Minds... Changing Lives

# ***“Talent and Economic Development Team”***

**Provost and College Deans**

**Representatives From**

- University Advancement
- Career Services
- Small Business Development Center
- Ralph Jaeschke  
Solutions for Economic Growth Center
- Corporate Engagement

# ***“Goals for Talent and Economic Development Team”***

- Create UW-Parkside asset map
- Define levels of engagement and alignment
- Develop strategies to leverage assets
- Create collateral to showcase UW-Parkside assets
- Create *“easy button”* connection to UW-Parkside



## ***“Goals for Talent and Economic Development Team”***

- Host CEO and HR professional round-table
- Leverage relationships with KABA, RCEDC, RAMAC, SHRM and partners to review needs and desires of area employers
- Submit proposals for UW Economic Incentive Program

# ***“Goals for Talent and Economic Development Team”***

- Maximize Ranger Link program
- Encourage faculty to document economic development activities; report levels of engagement
- Plan campus forum with Economic Development leaders

# ***“Economic Development Engagement”***

## **Regional Board Representation**

- KABA
- Kenosha Area Chamber of Commerce
- RCEDC
- RAMAC
- Kenosha and Racine County  
Workforce Development
- Milwaukee 7

# ***“Research Highlights”***

## Suresh Chalasani, MIS

- With Ictect – Intelligent Content Architectures for Healthcare, wireless monitoring for chronic diseases

## Susan Lincke, Computer Science

- With Engendren – Determining costs and energy efficiency of IT centers

## Derek Riley, Computer Science

- Mobile computing-based crowdsourcing simulations



# *“Wisconsin Center for Commercialization Resources”*

## **Strengthen Economic Development**

- Resources of five regional universities support WCCR to advance commercialization



UNIVERSITY OF WISCONSIN  
WHITEWATER



# ***“Wisconsin Center for Commercialization Resources”***

## **Serve Entire State of Wisconsin**

- Entrepreneurs
- First- and second-stage businesses
- Larger companies



# ***“Wisconsin Center for Commercialization Resources”***

## **Focus on Industry Clusters**

- Water
- Energy - Power and Control
- Health (including medical devices)

# ***“Alliance for Regional Development”***

## **Collaboration is Key**

## **Regional Initiatives -**

- Workforce Development, Transportation, Innovation and the Green Economy

## **Growing Support for Regionalism**

## **Focus –**

- Manufacturing
- Water – Aquaculture

